

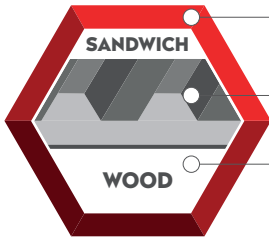

SANDWICH PANEL SCREW DP2

APPLICATION



SS A2 304

Sandwich Panels

Wood

SPECIFICATION

- 1 Head style 5/16" (8 mm)
- 2 Washer diameter standard 19 mm
- 3 SS EPDM bond seal
- 4 Support thread
- 5 Thread for substructure wood
- 6 Drilling point 2 reduced

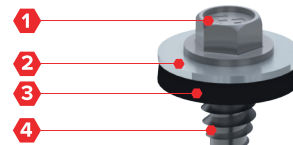

OPTIONS

- 1 Powder coated in any desired RAL colour
- 2 Washer diameter 16 or 22 mm

SECTION

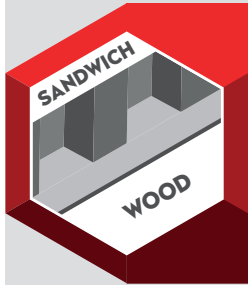
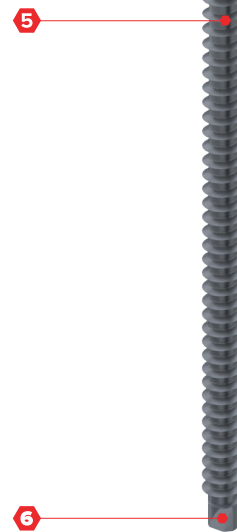
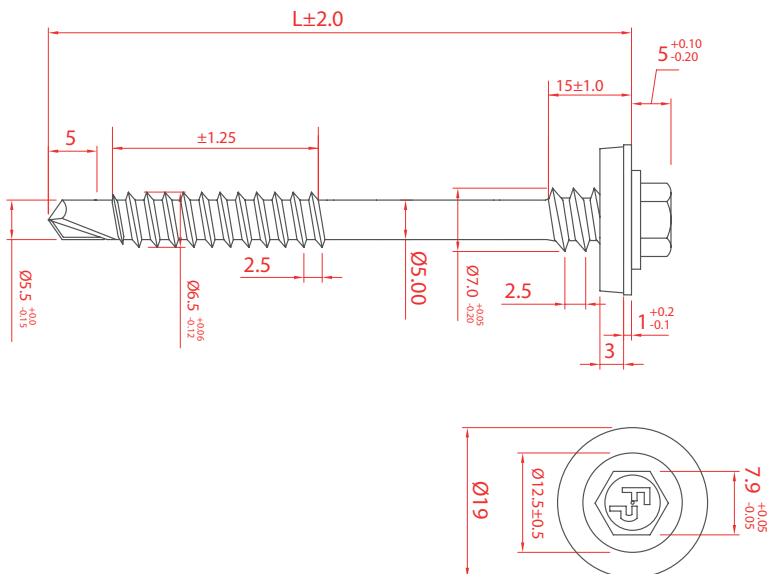

SANDWICH PANELS - WOOD - SS A2 304

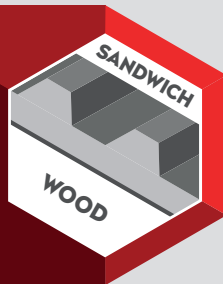
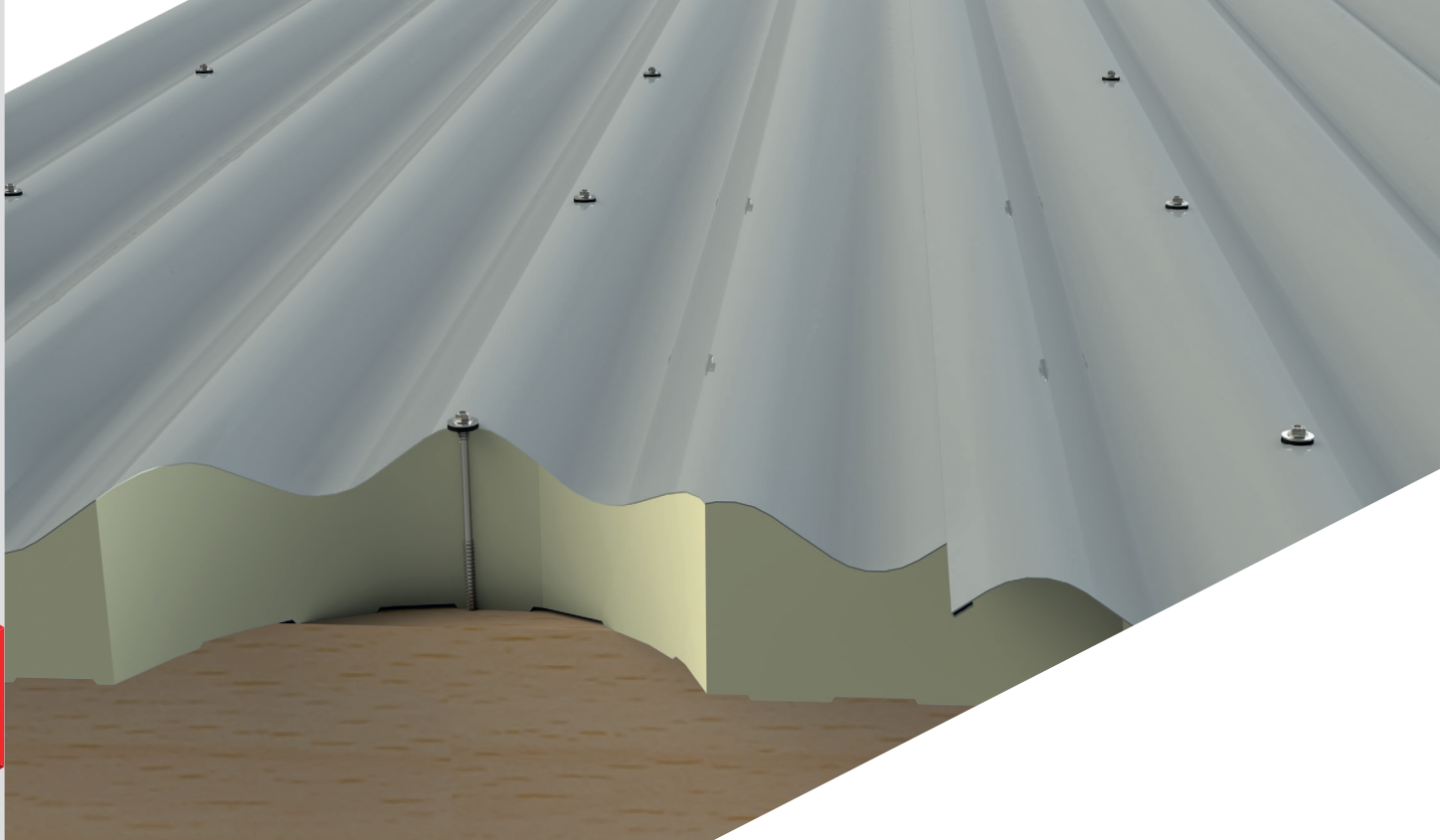

APPLICATION

Using the table below you can easily determine the sufficient screw length.

Size	Insulation thickness (mm)													Article code
	20	40	60	80	100	120	140	160	180	200	220	240	260	
6,3/7,0 x 60 mm	0 - 15 mm													1002026306019
6,3/7,0 x 75 mm	0 - 25 mm													1002026307519
6,3/7,0 x 100 mm	0 - 50 mm													1002026310019
6,3/7,0 x 125 mm	0 - 75 mm													1002026312519
6,3/7,0 x 145 mm	0 - 95 mm													1002026314519
6,3/7,0 x 165 mm	0 - 115 mm													1002026316519
6,3/7,0 x 185 mm	0 - 135 mm													1002026318519
6,3/7,0 x 205 mm	0 - 155 mm													1002026320519
6,3/7,0 x 225 mm	0 - 175 mm													1002026322519
6,3/7,0 x 245 mm	0 - 195 mm													1002026324519
6,3/7,0 x 265 mm	0 - 215 mm													1002026326519
6,3/7,0 x 300 mm	0 - 250 mm													1002026330019

SANDWICH PANELS - WOOD - SS A2 304



More information on materials, application, specific properties and certification can be found in chapter 10.

ORDER INFORMATION

Product	Size (L)	Packaging	Article code
Sandwich Panel Screw 6,3/7,0 x 60 – DP2	60 mm	100 pcs/box	1002026306019
Sandwich Panel Screw 6,3/7,0 x 75 – DP2	75 mm	100 pcs/box	1002026307519
Sandwich Panel Screw 6,3/7,0 x 100 – DP2	100 mm	100 pcs/box	1002026310019
Sandwich Panel Screw 6,3/7,0 x 125 – DP2	125 mm	100 pcs/box	1002026312519
Sandwich Panel Screw 6,3/7,0 x 145 – DP2	145 mm	100 pcs/box	1002026314519
Sandwich Panel Screw 6,3/7,0 x 165 – DP2	165 mm	100 pcs/box	1002026316519
Sandwich Panel Screw 6,3/7,0 x 185 – DP2	185 mm	100 pcs/box	1002026318519
Sandwich Panel Screw 6,3/7,0 x 205 – DP2	205 mm	100 pcs/box	1002026320519
Sandwich Panel Screw 6,3/7,0 x 225 – DP2	225 mm	100 pcs/box	1002026322519
Sandwich Panel Screw 6,3/7,0 x 245 – DP2	245 mm	100 pcs/box	1002026324519
Sandwich Panel Screw 6,3/7,0 x 265 – DP2	265 mm	100 pcs/box	1002026326519
Sandwich Panel Screw 6,3/7,0 x 300 – DP2	300 mm	100 pcs/box	1002026330019



**CERTIFICATES**

Deutsches
Institut
für
Bautechnik





QUALITY
CONFIRMED

SANDWICH PANEL SCREW 6,3/7,0 X L – DP2, WASHER DIAMETER Ø 16,0 MM

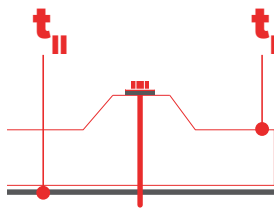
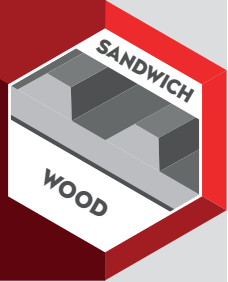
Materials		
Screw	Stainless steel 1.4301 (A2) – conform and ISO 3506	 European Technical Approval ETA 17/0293
Washer	Stainless steel 1.4301 (A2) – conform and ISO 3506	
Material A (t_I)	Steel Quality S280GD, S320GD and S350GD - conform EN 10346	 QUALITY CONFIRMED
Material B (t_{II})	Wooden Support conform DIN EN 338, ρ = 350 kg/m ² (min. C24)	
Drilling capacity	Wood	

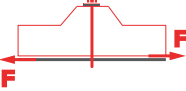

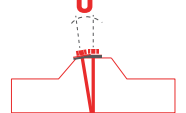

		t _{NI} [mm]	d, D [mm]									
			30	40	50	60	70	80	100	120	140	> 160
	V _{R,k} [kN]	0,40	1,03	1,03	1,03	1,03	1,03	1,03	1,03	1,03	1,03	1,03
		0,50	1,35	1,35	1,35	1,35	1,35	1,35	1,35	1,35	1,35	1,35
		0,55	1,51	1,51	1,51	1,51	1,51	1,51	1,51	1,51	1,51	1,51
		0,63	1,76	1,76	1,76	1,76	1,76	1,76	1,76	1,76	1,76	1,76
		0,75	2,14	2,14	2,14	2,14	2,14	2,14	2,14	2,14	2,14	2,14
		0,88	2,14	2,14	2,14	2,14	2,14	2,14	2,14	2,14	2,14	2,14
		1,00	2,14	2,14	2,14	2,14	2,14	2,14	2,14	2,14	2,14	2,14
	N _{R,k} [kN]	0,40	1,31	1,31	1,31	1,31	1,31	1,31	1,31	1,31	1,31	1,31
		0,50	1,39	1,39	1,39	1,39	1,39	1,39	1,39	1,39	1,39	1,39
		0,55	1,64	1,64	1,64	1,64	1,64	1,64	1,64	1,64	1,64	1,64
		0,63	2,03	2,03	2,03	2,03	2,03	2,03	2,03	2,03	2,03	2,03
		0,75	2,03	2,03	2,03	2,03	2,03	2,03	2,03	2,03	2,03	2,03
		0,88	2,03	2,03	2,03	2,03	2,03	2,03	2,03	2,03	2,03	2,03
		1,00	2,03	2,03	2,03	2,03	2,03	2,03	2,03	2,03	2,03	2,03
	u [mm]	-	8	8	10	12	14	16	20	24	28	32



Note

1. Above mentioned values are characteristic values
2. To determine the design value we advise to apply a material factor of γ_m = 1,33.
3. You can find further information and calculation examples on page 10.1.7

SANDWICH PANEL SCREW 6,3/7,0 X L – DP2, WASHER DIAMETER Ø 19,0 MM

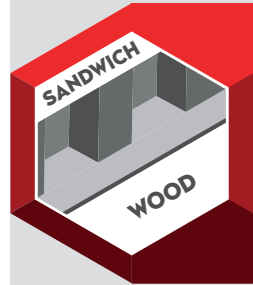
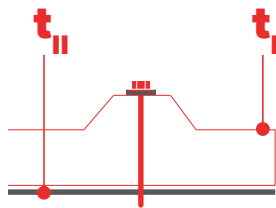
Materials		
Screw	Stainless steel 1.4301 (A2) – conform and ISO 3506	 European Technical Approval ETA 17/0293
Washer	Stainless steel 1.4301 (A2) – conform and ISO 3506	
Material A (t_I)	Steel Quality S280GD, S320GD and S350GD – conform EN 10346	 QUALITY CONFIRMED
Material B (t_{II})	Wooden Support conform DIN EN 338, $\rho = 350 \text{ kg/m}^3$ (min. C24)	
Drilling capacity	Wood	

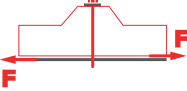



		t_{NI} [mm]	d, D [mm]									
			30	40	50	60	70	80	100	120	140	> 160
	$V_{R,k}$ [kN]	0,40	1,03	1,03	1,03	1,03	1,03	1,03	1,03	1,03	1,03	1,03
		0,50	1,35	1,35	1,35	1,35	1,35	1,35	1,35	1,35	1,35	1,35
		0,55	1,51	1,51	1,51	1,51	1,51	1,51	1,51	1,51	1,51	1,51
		0,63	1,76	1,76	1,76	1,76	1,76	1,76	1,76	1,76	1,76	1,76
		0,75	2,14	2,14	2,14	2,14	2,14	2,14	2,14	2,14	2,14	2,14
		0,88	2,14	2,14	2,14	2,14	2,14	2,14	2,14	2,14	2,14	2,14
		1,00	2,14	2,14	2,14	2,14	2,14	2,14	2,14	2,14	2,14	2,14
	$N_{R,k}$ [kN]	0,40	1,70	1,70	1,70	1,70	1,70	1,70	1,70	1,70	1,70	1,70
		0,50	1,70	1,70	1,70	1,70	1,70	1,70	1,70	1,70	1,70	1,70
		0,55	2,03	2,03	2,03	2,03	2,03	2,03	2,03	2,03	2,03	2,03
		0,63	2,03	2,03	2,03	2,03	2,03	2,03	2,03	2,03	2,03	2,03
		0,75	2,03	2,03	2,03	2,03	2,03	2,03	2,03	2,03	2,03	2,03
		0,88	2,03	2,03	2,03	2,03	2,03	2,03	2,03	2,03	2,03	2,03
		1,00	2,03	2,03	2,03	2,03	2,03	2,03	2,03	2,03	2,03	2,03
	u [mm]	-	8	8	10	12	14	16	20	24	28	32

Note

1. Above mentioned values are characteristic values
2. To determine the design value we advise to apply a material factor of $\gamma_m = 1,33$.
3. You can find further information and calculation examples on page 10.1.7

SANDWICH PANEL SCREW 6,3/7,0 X L – DP2, WASHER DIAMETER Ø 22,0 MM

Materials		
Screw	Stainless steel 1.4301 (A2) – conform and ISO 3506	 European Technical Approval ETA 17/0293
Washer	Stainless steel 1.4301 (A2) – conform and ISO 3506	
Material A (t_I)	Steel Quality S280GD, S320GD and S350GD - conform EN 10346	 QUALITY CONFIRMED
Material B (t_{II})	Wooden Support conform DIN EN 338, ρ = 350 kg/m ² (min. C24)	
Drilling capacity	Wood	

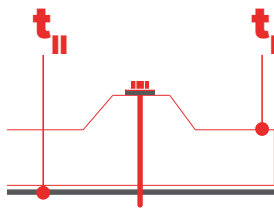
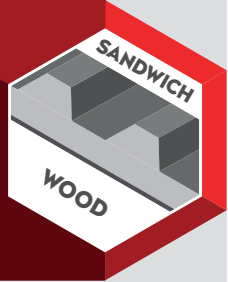

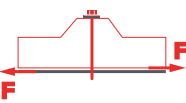
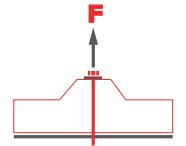
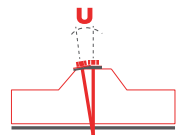
		t _{NI} [mm]	d, D [mm]									
			30	40	50	60	70	80	100	120	140	> 160
	V _{R,k} [kN]	0,40	1,03	1,03	1,03	1,03	1,03	1,03	1,03	1,03	1,03	1,03
		0,50	1,35	1,35	1,35	1,35	1,35	1,35	1,35	1,35	1,35	1,35
		0,55	1,51	1,51	1,51	1,51	1,51	1,51	1,51	1,51	1,51	1,51
		0,63	1,76	1,76	1,76	1,76	1,76	1,76	1,76	1,76	1,76	1,76
		0,75	2,14	2,14	2,14	2,14	2,14	2,14	2,14	2,14	2,14	2,14
		0,88	2,14	2,14	2,14	2,14	2,14	2,14	2,14	2,14	2,14	2,14
		1,00	2,14	2,14	2,14	2,14	2,14	2,14	2,14	2,14	2,14	2,14
	N _{R,k} [kN]	0,40	1,90	1,90	1,90	1,90	1,90	1,90	1,90	1,90	1,90	1,90
		0,50	2,03	2,03	2,03	2,03	2,03	2,03	2,03	2,03	2,03	2,03
		0,55	2,03	2,03	2,03	2,03	2,03	2,03	2,03	2,03	2,03	2,03
		0,63	2,03	2,03	2,03	2,03	2,03	2,03	2,03	2,03	2,03	2,03
		0,75	2,03	2,03	2,03	2,03	2,03	2,03	2,03	2,03	2,03	2,03
		0,88	2,03	2,03	2,03	2,03	2,03	2,03	2,03	2,03	2,03	2,03
		1,00	2,03	2,03	2,03	2,03	2,03	2,03	2,03	2,03	2,03	2,03
	u [mm]	-	8	8	10	12	14	16	20	24	28	32

Note

1. Above mentioned values are characteristic values
2. To determine the design value we advise to apply a material factor of γ_m = 1,33.
3. You can find further information and calculation examples on page 10.1.7