



# SELF-DRILLING TORX SCREW DP3

## APPLICATION



Bi-metal A2 304

Metal sheet Screw

Aluminium 1,5 to 5 mm

## SPECIFICATION

- 1 Head style Torx 25
- 2 Washer SS/EPDM 9 mm
- 3 Thread for substructure aluminium 1,5 to 5 mm
- 4 Drilling point 3 (hardened steel)

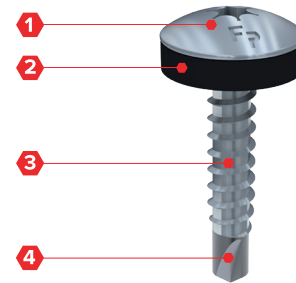

## OPTIONS

- 1 Powder coated in any desired RAL colour

## SECTION

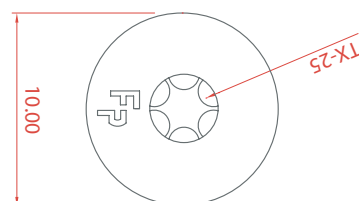
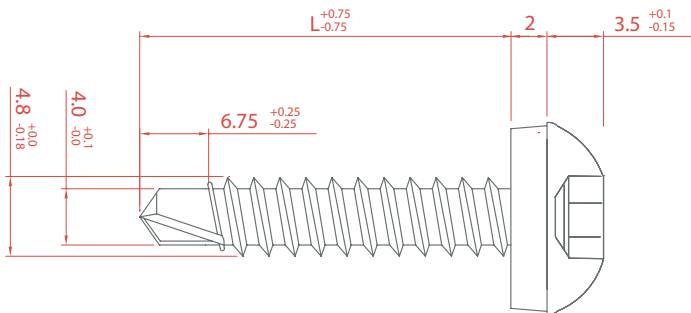

METAL SHEETS - ALUMINIUM 1,5 TO 5 MM - BI-METAL A2 304

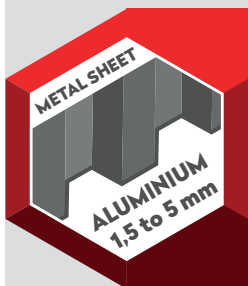

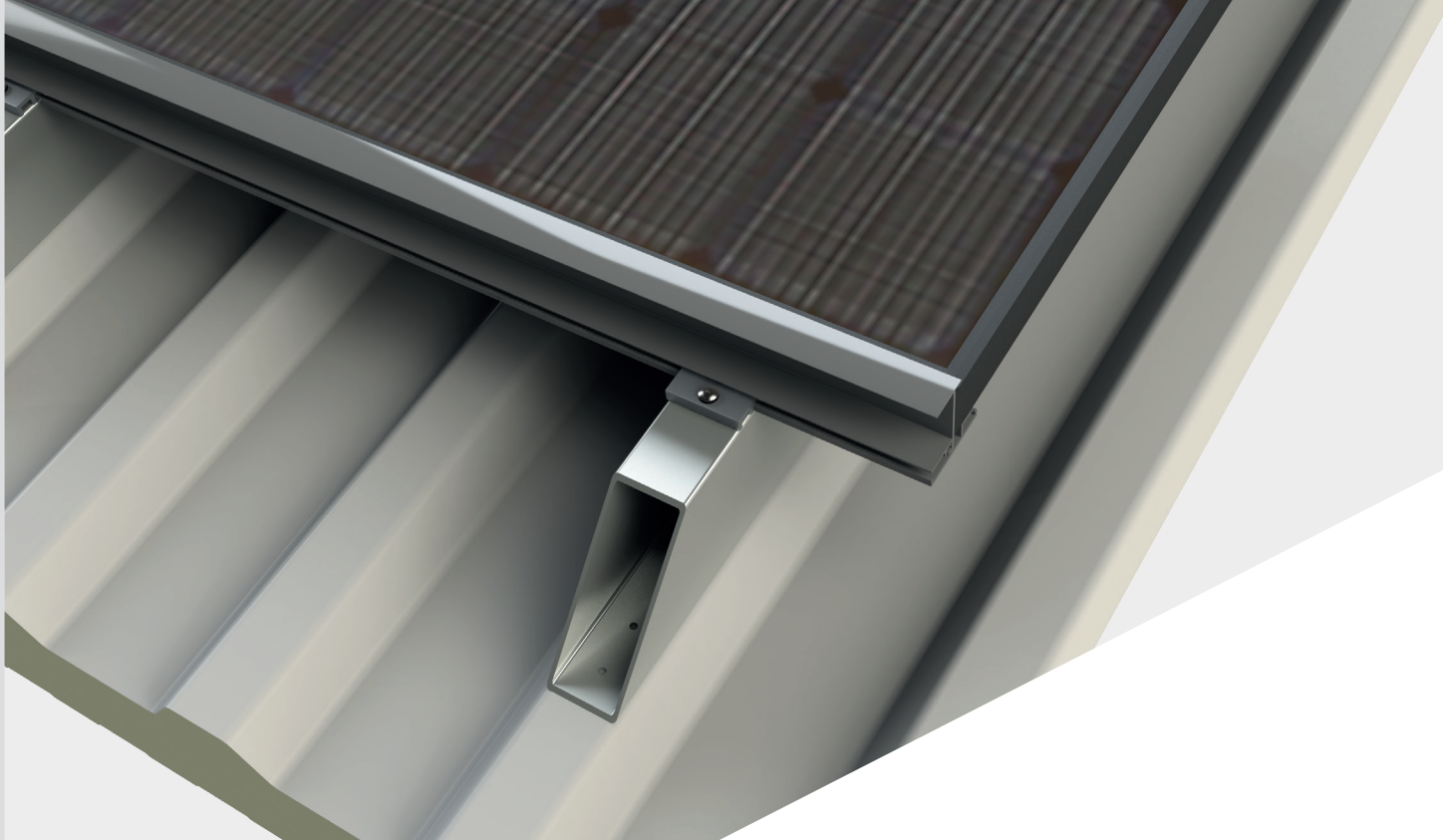

## ORDER INFORMATION

Product	Size (L)	Packaging	Article code
Self-Drilling torx Screw 4,8 x 20 - DP3	20 mm	500 pcs/box	20010348022M

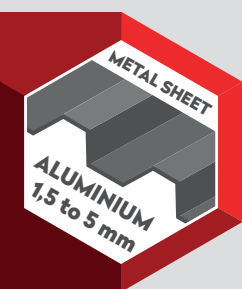

More information on materials, application, specific properties and certification can be found in chapter 10.



## CERTIFICATES





QUALITY  
CONFIRMED

SELF-DRILLING TORX SCREW 4,8 X L - DP3, WASHER DIAMETER Ø 10,0 MM

Materials	
Screw	SS 1.4301 (A2) - conform EN3506
Washer	SS 1.4301 (A2) - conform EN3506
Material A ( $t_{\perp}$ )	S280GD, S320GD and S350GD conform EN 10346
Material B ( $t_{\parallel}$ )	Aluminium Alloy and 573 Rm,min $\geq$ 215 N/mm <sup>2</sup>
Drilling capacity	Alu 215 $\leq$ 5 mm

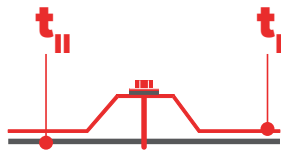

		$t_{\perp}$ [mm]	$t_{\parallel}$ [mm]						
			0,75	1,00	1,50	2,00	3,00	4,00	6,00
 $V_{R,k}$ [kN]	0,40	0,80	0,80	0,80	0,80	0,80	0,80	0,80	0,80
	0,50	0,88	0,88	0,88	0,88	0,88	0,88	0,88	0,88
	0,55	0,96	0,96	0,96	0,96	0,96	0,96	0,96	0,96
	0,63	1,08	1,08	1,08	1,08	1,08	1,08	1,08	1,08
	0,75	1,26	1,26	1,26	1,26	1,26	1,26	1,26	1,26
	0,88	1,26	1,46	1,46	2,14	2,14	2,14	2,14	2,14
	1,00	1,26	1,64	1,64	2,14	2,14	2,14	2,14	2,14
	1,13	1,26	1,64	1,61	2,14	2,14	2,14	2,14	2,14
	1,25	1,26	1,64	1,61	2,14	2,14	2,14	2,14	2,14
 $N_{R,k}$ [kN]	0,40	0,20	0,31	0,79	1,23	1,30	1,30	1,30	1,30
	0,50	0,20	0,31	0,79	1,23	1,88	2,16	2,16	2,16
	0,55	0,20	0,31	0,79	1,23	1,88	2,36	2,36	2,36
	0,63	0,20	0,31	0,79	1,23	1,88	2,60	2,60	2,60
	0,75	0,20	0,31	0,79	1,23	1,88	2,60	2,60	2,60
	0,88	0,20	0,31	0,79	1,23	1,88	2,60	2,60	2,60
	1,00	0,20	0,31	0,79	1,23	1,88	2,60	2,60	2,60
	1,13	0,20	0,31	0,79	1,23	1,88	2,60	2,60	2,60
	1,25	0,20	0,31	0,79	1,23	1,88	2,60	2,60	2,60

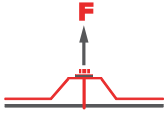
**Note**

1. Above mentioned values are characteristic values.
2. To determine the design value we advise to apply a material factor of  $\gamma_m = 1,33$ .
3. You can find further information and calculation examples on page 10.1.7.
4. The mechanical properties in combination with an aluminium support in  $R_m \geq 165$  N/mm<sup>2</sup> quality are available on request. Please contact our internal sales department for more information.

