

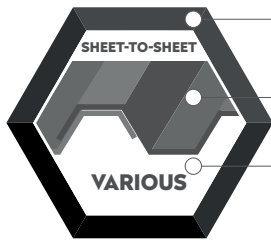

STANDARD BLIND RIVET ALUMINIUM / ALUMINIUM

APPLICATION



Aluminium / Aluminium

Sheet-to-sheet

Various

SPECIFICATION

- 1 Mandrel head (aluminium)
- 2 Rivet body (aluminium)
- 3 Nail head (aluminium)
- 4 Mandrel (aluminium)

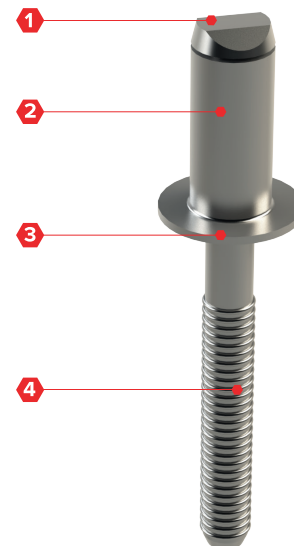

OPTIONS

- 1 Powder coated in any desired colour

SECTION

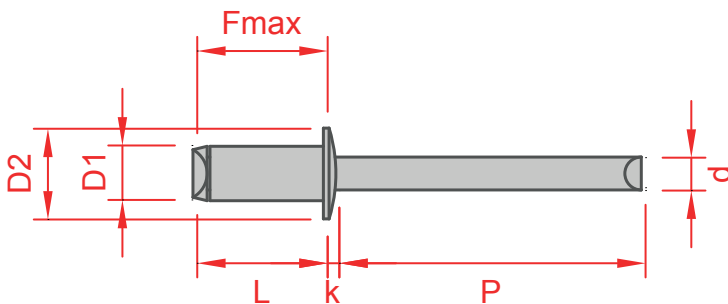

STITCHING SCREWS - ALUMINIUM/ALUMINIUM

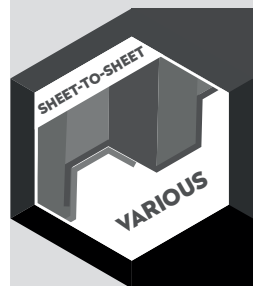



APPLICATION

Using the table below you can easily determine the sufficient blind rivet length.

Size	Thickness (mm)													Article code				
	0,5	1,0	2,0	3,0	4,0	5,0	6,0	7,0	8,0	9,0	10,0	12,0	14,0		16,0	18,0	20,0	22,0
4,8 x 12 mm																		2015048012

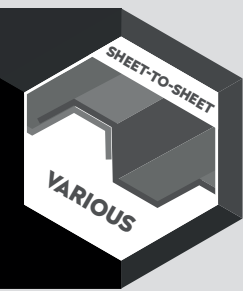

CERTIFICATES



QUALITY
CONFIRMED



STANDARD BLIND RIVET ALUMINIUM / ALUMINIUM

DIMENSIONS

Product	D1	D2	d	P	k	L	Fmax	Pre-drill
Standard blind rivet, 4,8 x 12 mm, AL/AL	4,8	9,5	2,9	≥ 27 mm	1,1	12	17,4	4,9

MECHANICAL PROPERTIES

Product	Shear force	Tensile strength
Standard blind rivet, 4,8 x 12 mm, AL/AL	1150 N	1420 N

ORDER INFORMATION

Product	Size	Packaging	Article code
Standard blind rivet, 4,8 x 12 mm, AL/AL	4,8 x 12 mm	500 pcs	2015048012

Other types and measurements available on request.

